

# Monitor Slider<sup>01/02</sup>

PARTS AND TOOLS

(A) ×1 PCE

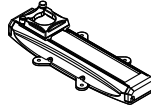

(B) ×4 PCS



(C) ×4 PCS



(D) ×4 PCS



To mount your flat panel monitor or any parts at an ergonomically correct position, start at step 1 and continue as directed.

CAUTION

- Before assembling, please check assembly guide thoroughly to avoid any mistake.
- 4006000102: 4006060601: Weight capacity :3.5-5.5kg LCD monitors.
- 4006000101: 4006000201: Weight capacity :5-7kg LCD monitors.
- Standard products include several small parts, keep out of children when assemble this product and prevent children from swallowing them.

STEP 1

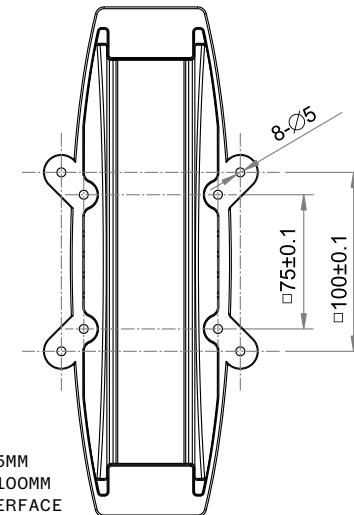
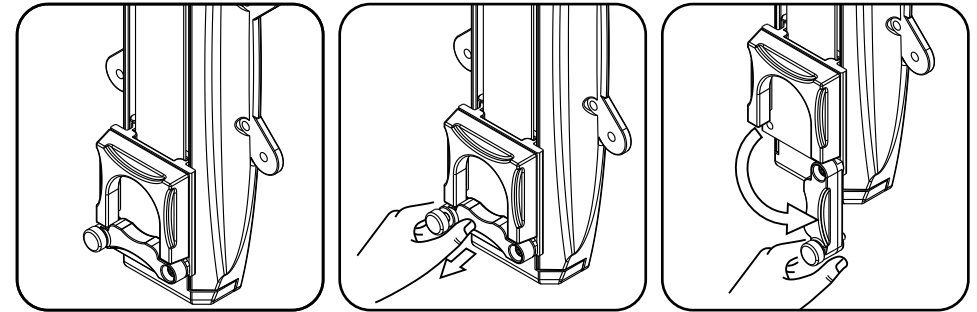

75MM × 75MM  
100MM × 100MM  
VESA INTERFACE

**STEP 2**

Place LCD with facing downward on flat surface. Place VESA on the LCD back as figure and align to the screw holes. Secure them together with four screws and then tighten them up with screwdriver (Not provided).

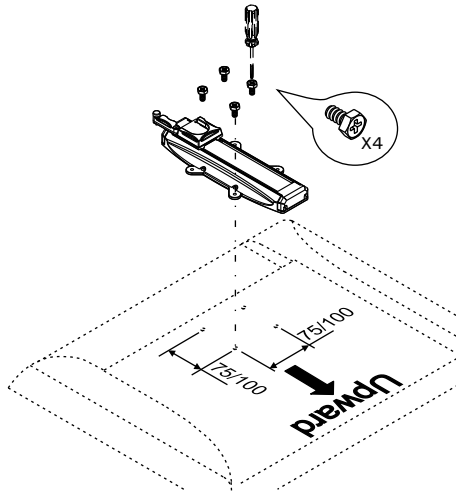

THESE SCREWS (M4/15L) ARE JUST FOR SPECIAL MONITORS WHEN THE ORIGINAL SCREWS ARE TOO SHORT TO FASTEN.



Before assembling, make sure if there's any groove inside of the pitch of the LCD. If yes please put bushings in the groove, place VESA on the LCD back as figure and align to the screw holes. Secure them together with four screws and then tighten them up with screwdriver (Not provided).

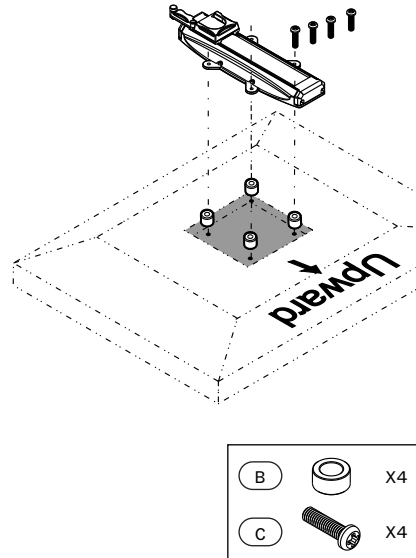

**STEP 3**

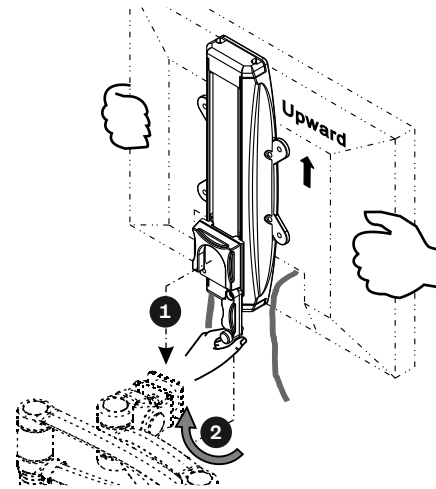

Insert the VESA (with LCD display on already) into the arm and press it down. Then secure fixing lump on VESA with knob. (As figure down step 1, 2, 3)

ADJUSTABLE:

