

SmartVision40 Installation and Deployment Guide

Package Contents

TIP

- We recommend that you use the accessories provided or approved by Yealink. The use of unapproved third-party accessories may result in poor performance.
- Use the Yealink original power adapter to charge the endpoint only. The use of the third-party power adapter may cause damage to the endpoint.

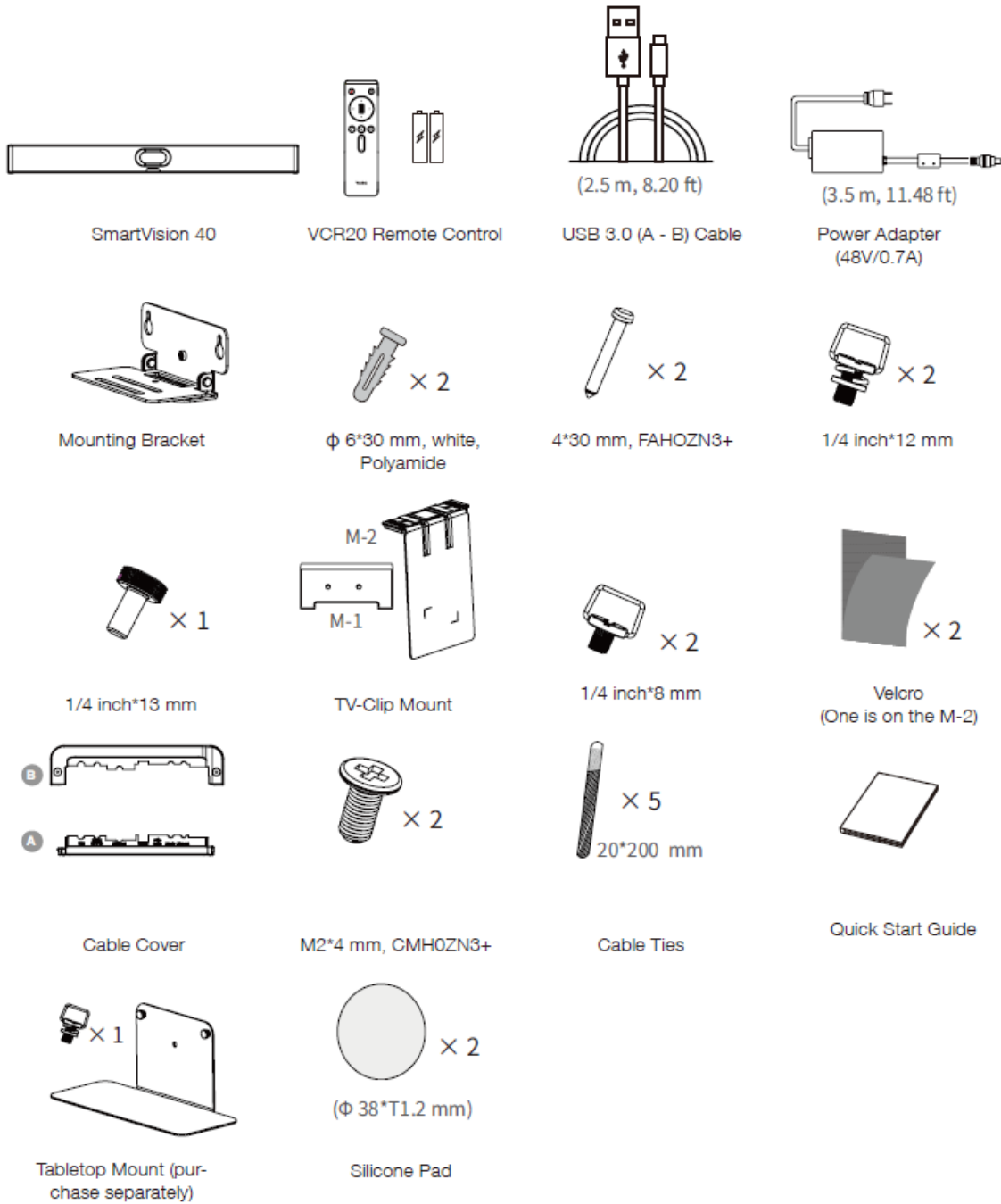

Assemble Cable Cover

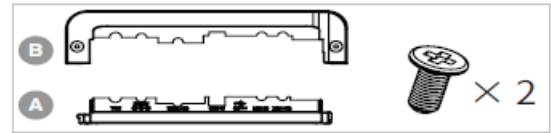

- 1 Find the two slots on the back of SmartVision 40.

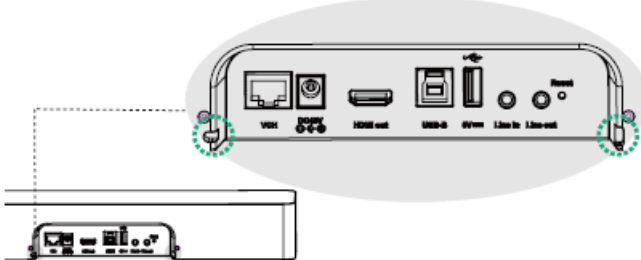

- 2 Fit part A of the cable cover into the slots.



- 3 Connect cables.

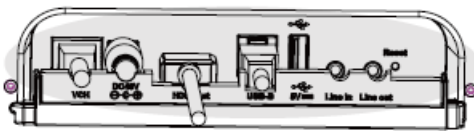

- 4 Assemble part B and fix the screws.

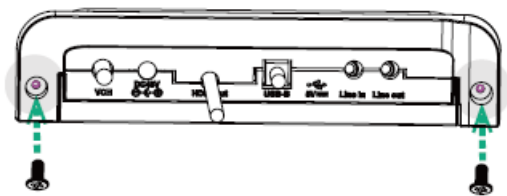

Install SmartVision 40

Install SmartVision 40

NOTE

It is recommended to deploy SmartVision 40 at least **1m** from the front row of participants.

- **Put on a Flat Surface**

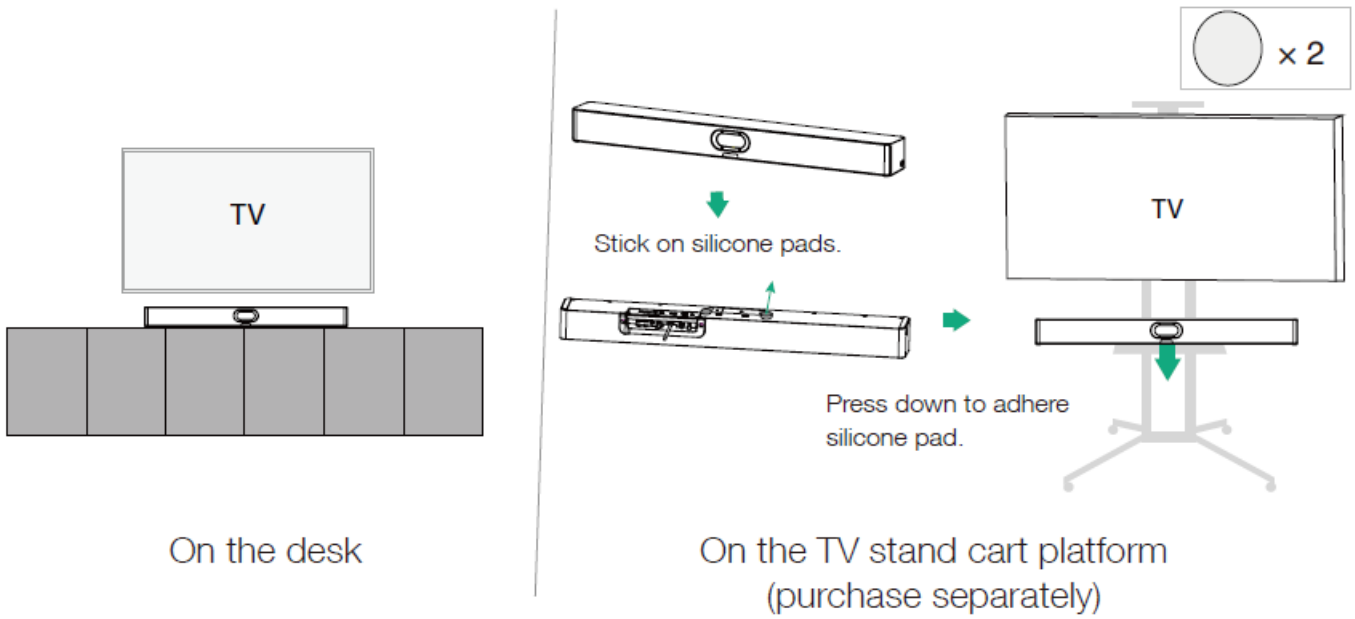

- **Mount on a Wall**

Step 1: Determine SmartVision 40 position

The mounting height affects your camera view. The recommended height is 110 cm above the ground.

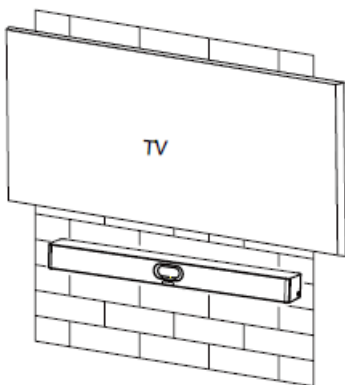

Step 2: Mount the SmartVision 40 to the wall

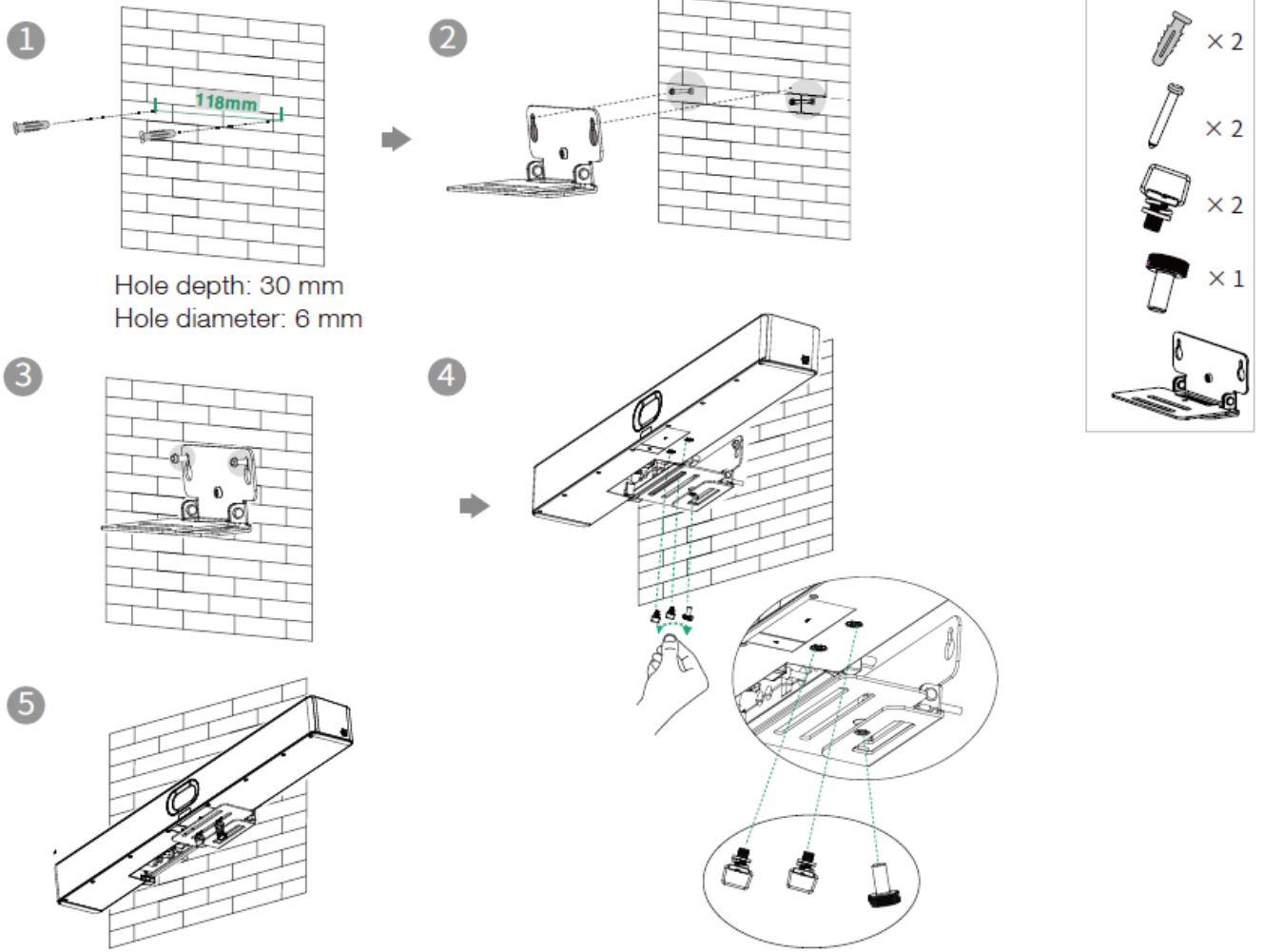

This deployment plan meets the ADA regulatory requirements in the United States.

• **Embed in the wall**

The mounting height affects your camera view. The recommended height is 110 cm above the ground.

ⓘ **NOTE**

- Keep the front of the SmartVision 40 flush with the wall surface.
- The recommended on the left, right, and top sides of the SmartVision 40 is less than 0.5 cm.
- Leave a 5 ± 0.5 cm distance between the back of the SmartVision 40 and the wall surface for cable connections.

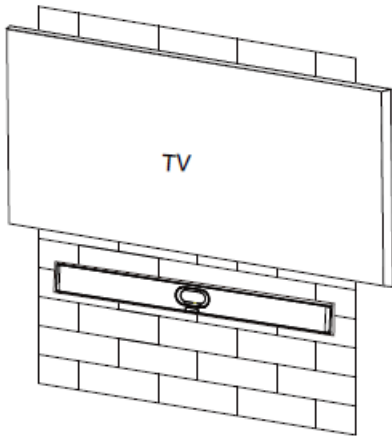

• **Mount on the Tabletop Mount**

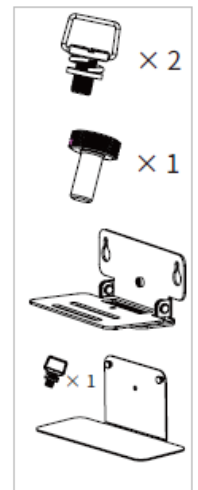
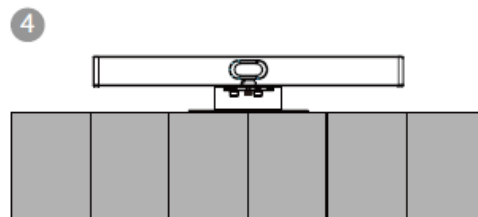
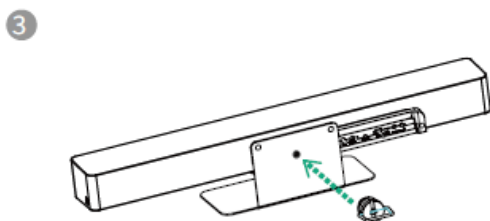
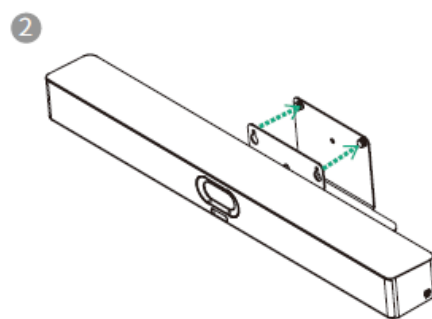
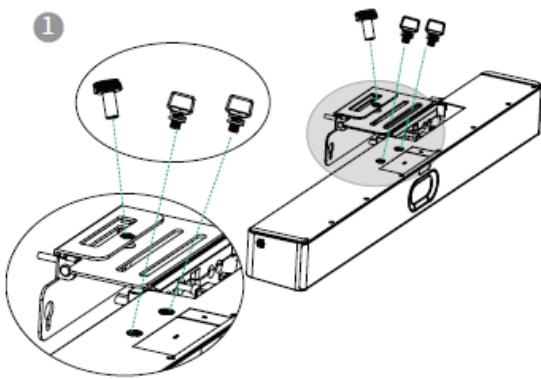

• Mount above a TV or a display

NOTE

- The M-2 bracket can be inserted into the M-1 in two directions. Here, we will focus on one direction for illustration.
- Due to device weight, it is advisable to avoid mounting the device on slim TVs to prevent potential falls or damage to the screen.

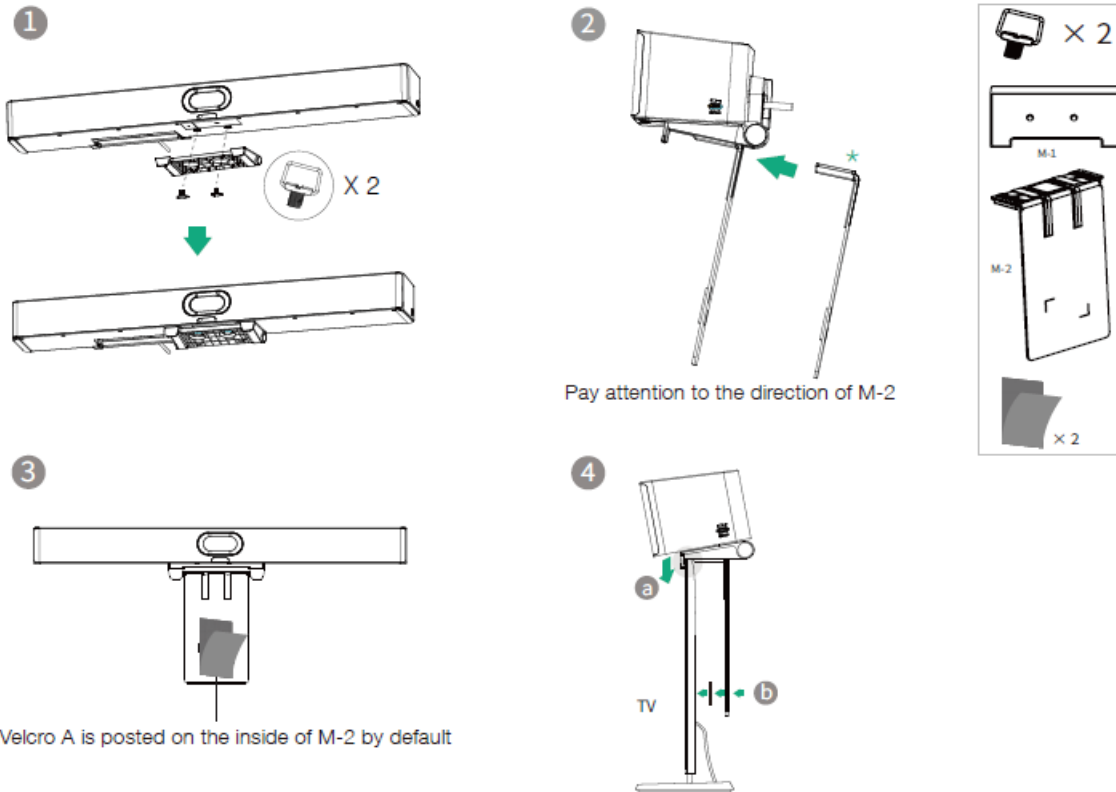

Adjust Camera Tilt

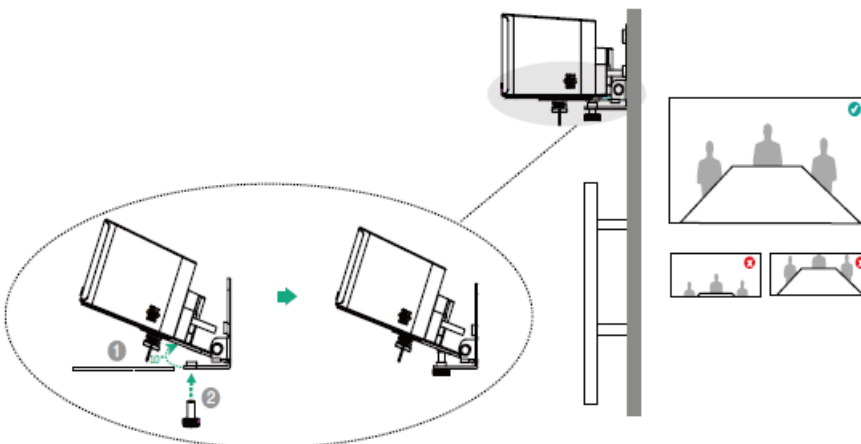

Remote Control and Cable Ties Installation

Remote Control Installation

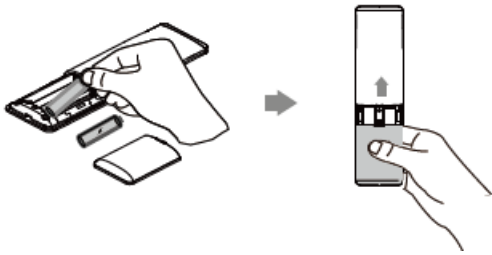

Cable Ties Installation

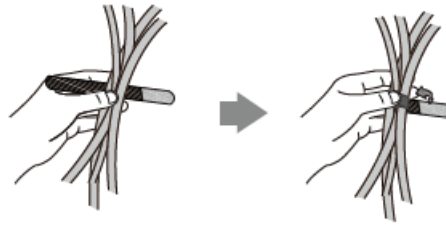

Hardware Interface

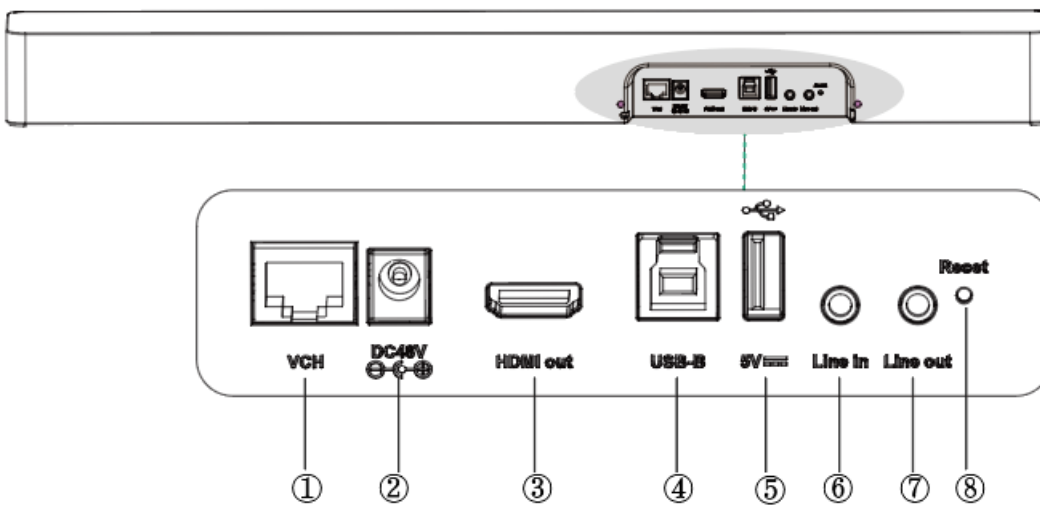

No.	Item	Description
1	VCH	Connect to microphones or MVC-BYOD-Extender.
2	DC48V	Connect to a power adapter.
3	HDMI Out	Reserved port for future features.
4	USB Type-B (USB 3.0)	Connect to a PC as video output.
5	USB Type-A (USB 2.0)	Connect to USB flash driver to export device log.
6	Line In	Connect a 3.5mm audio connector to use the SmartVision 40 as an audio output device.
7	Line Out	Connect a 3.5mm audio connector to output audio to the hearing assistance system.
8	Reset	Reset the SmartVision 40 to factory defaults.

Connect SmartVision 40

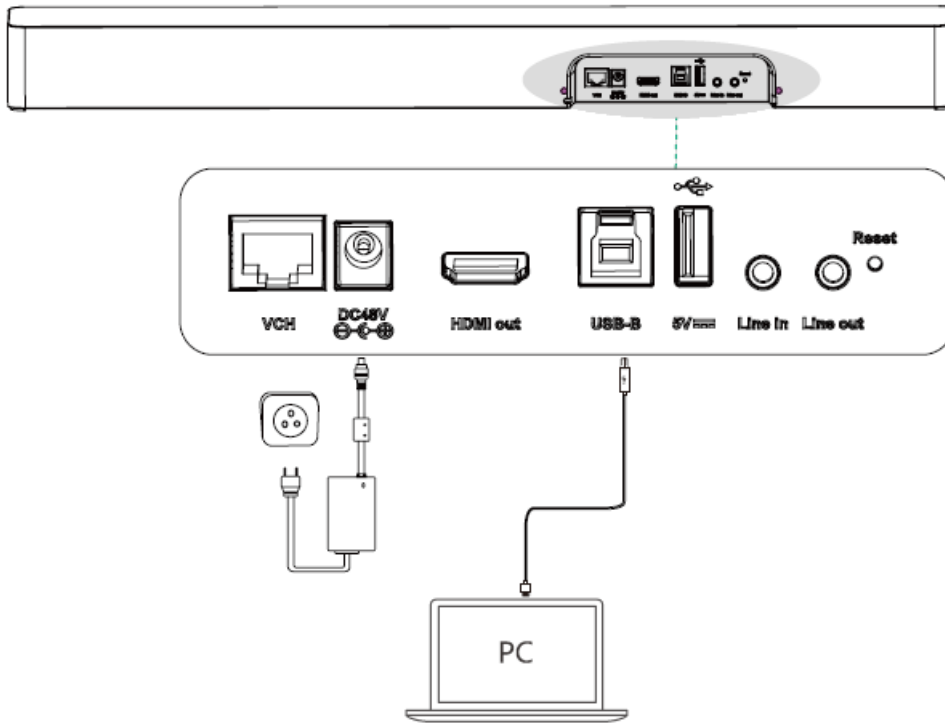

LED Indicator

LED Status	Description
Off	The SmartVision 40 is not properly connected to the mini-PC.
Flashing green	There is an incoming call.
Solid green	The SmartVision 40 is active.
Solid red	The SmartVision 40 is muted.
Solid orange	The SmartVision 40 is initializing or in sleep mode.
Flash orange	The SmartVision 40 is upgrading firmware.
Flash red and green alternately	The SmartVision 40 is paired with the VCM36-W.
Flash red	The SmartVision 40 is in recovery mode, and the firmware has not been upgraded.