

INSTRUCTION SHEET

TS SERIES

TELESCOPING SERVICE STAND

PARTS

(1) Ball Driver 

HARDWARE KIT (Part # 91-067)

(6) Screw 10-32 x 5/8

(1) Hex Wrench

TS1640/TS1022 ASSEMBLY

- 1) Adjust the telescoping section of the track stand to the approximate height of the AXS base, and secure with the locking pins.
- 2) Place the front of the service track (TRACK50/TRACK25/TRACK31) on the cabinet opening and the rear on the service stand saddle. Ensure that the TRACK is level.
- 3) Bolt the service track to the AXS rough-in-pan using 10-32 hex cap screws and ball driver.
- 4) Level the service stand and lock it into place using the adjustment lever.

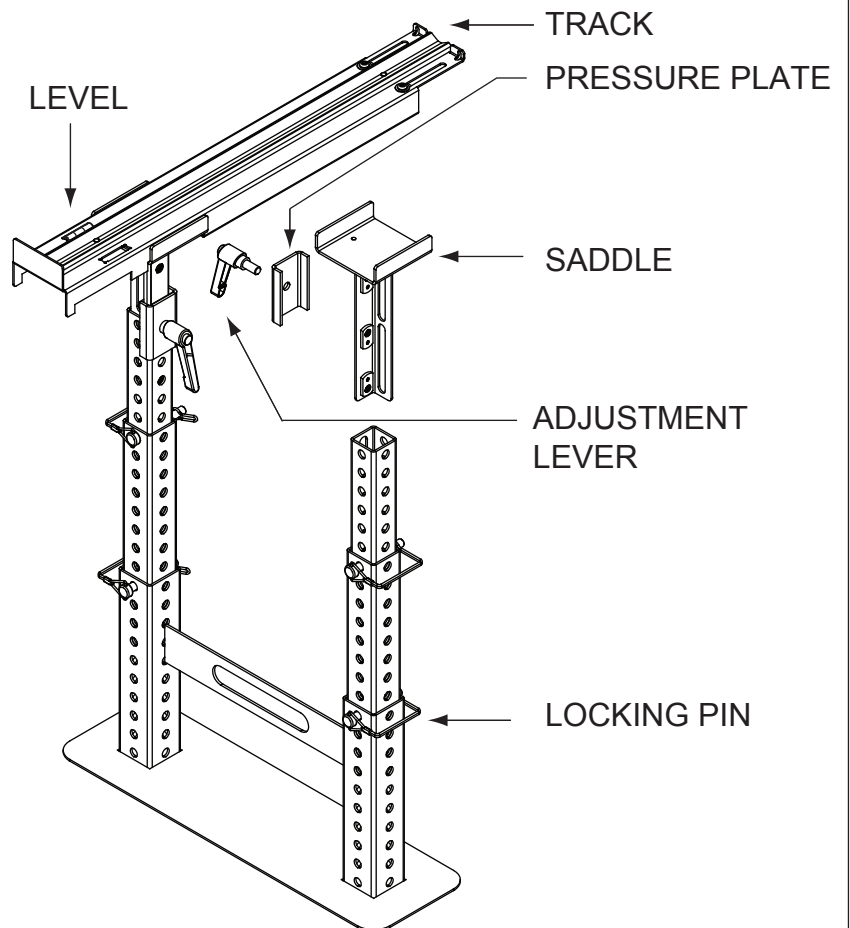

TS310 ASSEMBLY ON NEXT PAGE

TS310 ASSEMBLY

- 1) Adjust the saddle section of the track stand to the approximate height of the AXS base, and secure with the locking pins.
- 2) Place the front of the service track (TRACK50/TRACK25/TRACK31) on the cabinet opening and the rear on the service stand saddle. Ensure that the TRACK is level.
- 3) Bolt the service track to the AXS rough-in-pan using 10-32 hex cap screws and ball driver.
- 4) Level the service stand by adjusting the leveling feet with the 3/16 hex key provided.

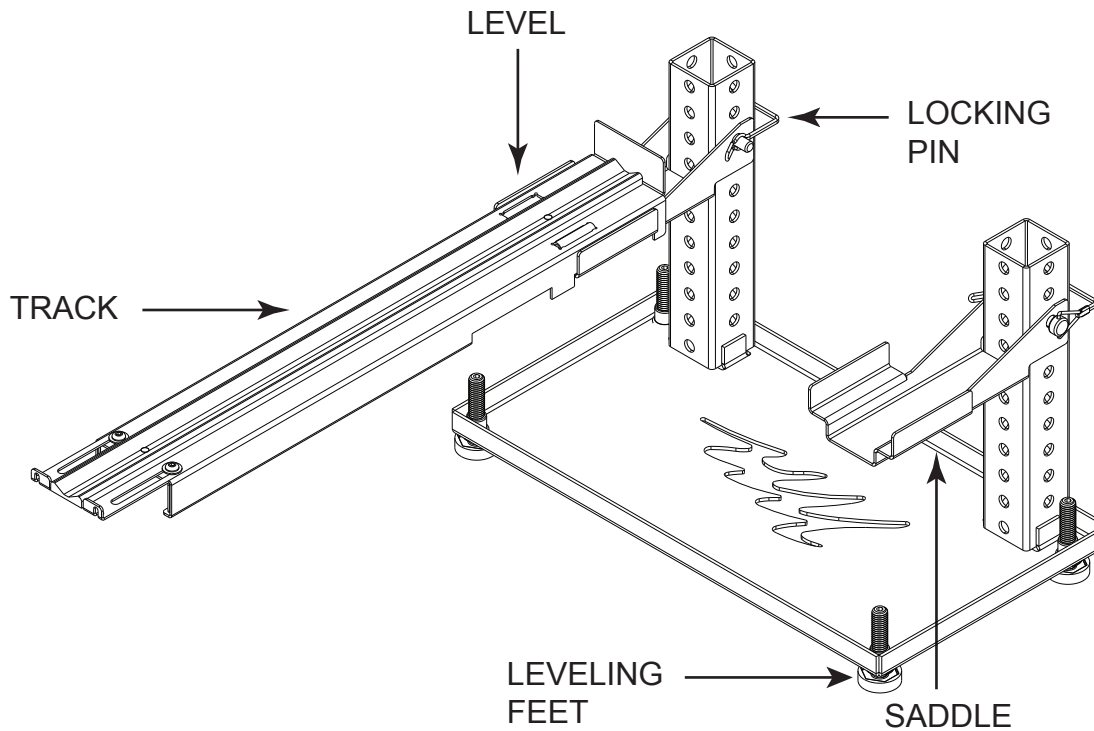

WARRANTY

Middle Atlantic Products (the "Company") warrants the TS Series Telescoping Service Stand to be free from defects in material or workmanship under normal use and conditions for the lifetime of the product.

The Company's entire liability to the purchaser, and the purchaser's (or any other party's) sole and exclusive remedy, under this warranty shall be limited, at the Company's option, to either (a) return of and refund of the price paid for, or (b) repair or replacement at the Company's factory of the products purchased, or any part or parts thereof, which the Company has determined to be defective after inspection thereof at the Company's factory.

This warranty does not cover damage due to acts of God, accident, misuse, abuse or negligence by parties other than the Company, or any modification or alteration of the products. In addition, this warranty does not cover damage due to improper handling, assembly, installation or maintenance.

THIS WARRANTY IS IN LIEU OF ALL OTHER WARRANTIES OF ANY KIND, EITHER EXPRESSED OR IMPLIED, INCLUDING, BUT NOT LIMITED TO, IMPLIED WARRANTIES OF MERCHANTABILITY AND FITNESS FOR A PARTICULAR PURPOSE.

TO THE MAXIMUM EXTENT PERMITTED BY APPLICABLE LAW, IN NO EVENT SHALL THE COMPANY BE LIABLE FOR ANY SPECIAL, INCIDENTAL, INDIRECT, OR CONSEQUENTIAL DAMAGES WHATSOEVER (INCLUDING, WITHOUT LIMITATION, DAMAGES FOR LOSS OF BUSINESS PROFITS, BUSINESS INTERRUPTION OR ANY OTHER PECUNIARY LOSS) ARISING OUT OF THE USE OF THE PRODUCTS PURCHASED, EVEN IF THE COMPANY HAS BEEN ADVISED OF THE POSSIBILITY OF SUCH DAMAGES. THE COMPANY'S LIABILITY TO THE PURCHASER (OR ANY OTHER PARTY) HEREUNDER, IF ANY, SHALL IN NO EVENT EXCEED THE PURCHASE PRICE OF THE PRODUCTS PAID TO THE COMPANY.

Corporate Headquarters

Corporate Voice 973-839-1011 - Fax 973-839-1976
International Voice +1 973-839-8821 - Fax +1 973-839-4982
middleatlantic.com - info@middleatlantic.com

Middle Atlantic Canada

Voice 613-836-2501 - Fax 613-836-2690
middleatlantic.ca - customerservicecanada@middleatlantic.ca

Factory Distribution

USA: NJ - CA - IL Canada: ON - BC

At Middle Atlantic Products we are always listening. Your comments are welcome. Middle Atlantic Products is an ISO 9001 and ISO 14001 Registered Company.

