

SAMI-402

ANALOGUE PREAMPLIFIERS & MIXERS
Installation Mixers



USER MANUAL



| |
|------------------------|
| PRECAUTIONS |
| WARRANTY & ENVIRONMENT |
| PACKAGE CONTENTS |
| DESCRIPTION & FEATURES |
| INSTALL & CONNECT |
| START-UP & OPERATION |
| PANEL FUNCTIONS |
| TECHNICAL DATA |

TABLE OF CONTENTS

| | |
|---|-----------|
| 1. PRECAUTIONS..... | 3 |
| 1.1 Important Notice..... | 3 |
| 1.2 Key Safety Directions..... | 4 |
| 1.3 Cleaning Directions..... | 4 |
| 2. WARRANTY & ENVIRONMENT | 5 |
| 3. PACKAGE CONTENTS | 5 |
| 4. DESCRIPTION & FEATURES | 6 |
| 4.1 Main Features..... | 6 |
| 5. INSTALL & CONNECT | 7 |
| 6. START-UP & OPERATION..... | 8 |
| 6.1 Connections | 8 |
| 6.1.1 Inputs | 8 |
| 6.1.2 Outputs..... | 10 |
| 6.1.3 Other connections on the back panel | 11 |
| 6.2 Starting-up..... | 12 |
| 6.3 Equalization..... | 12 |
| 6.4 VU-Meter | 12 |
| 6.5 Ground Loops, Background noise..... | 13 |
| 7. PANEL FUNCTIONS..... | 14 |
| 7.1 Front Panel..... | 14 |
| 7.2 Rear Panel | 14 |
| 8. TECHNICAL DATA..... | 15 |
| 8.1 Technical Specifications..... | 15 |
| 8.2 Mechanical Diagram..... | 17 |

| |
|---|
|  |
| PRECAUTIONS |
| WARRANTY & ENVIRONMENT |
| PACKAGE CONTENTS |
| DESCRIPTION & FEATURES |
| INSTALL & CONNECT |
| START-UP & OPERATION |
| PANEL FUNCTIONS |
| TECHNICAL DATA |

1. PRECAUTIONS

1.1 Important Notice



WARNING: SHOCK HAZARD - DO NOT OPEN

AVIS: RISQUE DE CHOC ÉLECTRIQUE - NE PAS OUVRIR



The flashing light with an arrowhead symbol inside an equilateral triangle on it is intended to alert the user of the presence of non-insulated “dangerous voltage” within the enclosure, which might be of sufficient magnitude to pose a risk of electric shock to users.



The exclamation mark within an equilateral triangle is intended to alert the user of the requirement for important operating and maintenance (servicing), for which instructions may be found in the literature accompanying the appliance.

WARNING (If applicable): Terminals marked with symbol “” may be of sufficient magnitude to pose a risk of electric shock. The external wiring connected to terminals requires installation by a technician, or the use of ready-made leads or cords.

WARNING: To prevent fire or shock hazard, do not expose this equipment to rain or humidity.

WARNING: A device with Class I manufacturing ought to be connected to a mains socket outlet with a protective earthing connection.



WARNING: Ecler products have a long lifetime of more than 10 years. This product must never be discarded as unsorted urban waste, but must be taken to the nearest electrical and electronic waste treatment centre.

| | |
|--|------------------------|
| | PRECAUTIONS |
| | WARRANTY & ENVIRONMENT |
| | PACKAGE CONTENTS |
| | DESCRIPTION & FEATURES |
| | INSTALL & CONNECT |
| | START-UP & OPERATION |
| | PANEL FUNCTIONS |
| | TECHNICAL DATA |

1.2 Key Safety Directions

1. Read the following directions.
2. Keep the following directions.
3. Heed all warnings.
4. Follow all directions.
5. Do not use this device in proximity to water.
6. Clean only with a dry cloth.
7. Do not block any ventilation openings. Install in accordance with the manufacturer's instructions.
8. Do not install near any heat sources such as radiators, heat registers, stoves, or other devices (including amplifiers) that may release heat.
9. Do not defeat the safety purpose of the polarized or grounding type plug. A polarized plug has two blades, being one wider than the other. A grounding type plug has two blades and a third grounding prong. The wide blade or the third prong are provided for your safety. If the provided plug does not fit into your outlet, contact a qualified electrician for a replacement of the obsolete outlet.
10. Protect the power cord from being walked on or pinched, particularly at the plugs, convenience receptacles, and at the point of exit from the device.
11. Only use attachments/accessories specified by the manufacturer.
12. Unplug the device during lightening sorts or when unused for long periods of time.
13. Refer all servicing to qualified personnel. Servicing is required when the device has been damaged in any way, such as power supply cord or plug damage, liquid spillage or objects onto the device, the device has been exposed to rain or humidity, does not operate normally, or has been dropped.
14. Disconnecting from mains: When switching off the POWER switch, all the functions and light indicators of the unit will be stopped, but fully disconnecting the device from mains is done by unplugging the power cable from the mains input socket, therefore, it should always remain easily accessible
15. Equipment is connected to a socket-outlet with an earthing connection by means of a power cord.
16. The marking information is located at the bottom/rear of the unit.
17. The device shall not be exposed to dripping or splashing liquids, and no liquid-filled objects, such as a filled up glass, shall be placed on top of the device.

1.3 Cleaning Directions



Clean the unit with a soft, dry clean cloth or slightly wet with water and neutral liquid soap only, then dry it with a clean cloth. Be careful that water never gets into the unit through any hole. Never use alcohol, benzine, solvents or abrasive substances to clean this unit.

NEEC AUDIO BARCELONA, S.L. accepts no liability for any damage that may be caused to people, animal, or objects due to failure to comply with the warnings above.

| | |
|---|------------------------|
|  | PRECAUTIONS |
| | WARRANTY & ENVIRONMENT |
| | PACKAGE CONTENTS |
| | DESCRIPTION & FEATURES |
| | INSTALL & CONNECT |
| | START-UP & OPERATION |
| | PANEL FUNCTIONS |
| | TECHNICAL DATA |

2. WARRANTY & ENVIRONMENT

**Thank you for choosing our Ecler SAMI-402!
We greatly value your trust.**

It is **VERY IMPORTANT** to carefully read this manual and to fully understand its **contents before any connecting takes place** in order to make the best use of this equipment, as well as to get the best performance from it.

To ensure optimal operation of this device, **we strongly recommend that its maintenance be carried out by our authorised Technical Services.**

All ECLER products are covered by warranty, please refer to www.ecler.com or the warranty card included with this product for the period of validity and conditions.



Ecler is truly committed with the environment and planet sustainability, energy saving and CO₂ emission reduction. Recycling materials and using non-contaminant components are also top priorities in our green crusade.

Ecler has deeply evaluated and analyzed the environmental impacts of all the processes involved in the production of this product, including packaging, and has alleviated, reduced and/or compensated for them.

3. PACKAGE CONTENTS

- ±17.5VDC external multi-plug PSU.
- EuroBlock connectors.
- Rubber Feet.
- Mini Jumpers.
- First Steps Guide.
- Warranty card.

| |
|---|
|  |
| PRECAUTIONS |
| WARRANTY & ENVIRONMENT |
| PACKAGE CONTENTS |
| DESCRIPTION & FEATURES |
| INSTALL & CONNECT |
| START-UP & OPERATION |
| PANEL FUNCTIONS |
| TECHNICAL DATA |

4. DESCRIPTION & FEATURES

SAMI-402 is an installation audio mixer in standard rack format, featuring 3 MIC/LINE Stereo inputs, 1 LINE Stereo input, 1 main mix output and one AUX/REC additional output.

It includes a 3 band tone control section, Talkover (priority) function assignable to each MIC/LINE input over the mix bus, ST/MONO mix switch and MUTE port for external dry contact triggering.

4.1 Main Features

- 4 input channels, 2 outputs 19" installation mixer.
- 3 MIC/LINE stereo inputs.
- 1 LINE stereo input.
- 1 main mix output and one AUX/REC additional output.
- 3 band tone control section.
- Talkover (priority) function assignable from each MIC/LINE input over the mix.
- Micro sensitivity level can be adjusted on the back panel.
- +18V Phantom Power available for all MIC inputs.
- MUTE remote control input enabled by external dry contact closure that allows connection of fire detection systems and other safety devices that have to mute the mixer by using this control signal.
- Universal external power supply (multi-plug).



PRECAUTIONS

WARRANTY
&
ENVIRONMENT

PACKAGE
CONTENTS

DESCRIPTION
&
FEATURES

INSTALL
&
CONNECT

START-UP
&
OPERATION

PANEL
FUNCTIONS

TECHNICAL
DATA

5. INSTALL & CONNECT

The SAMI-402 mixer has been specially designed to be installed in a standard 19" rack, taking up 1U. It has been designed to be operated by non-technical users. This is the reason why its tone controls are adjustable only with a screwdriver. On the opposite, input and output level controls use classic and easily accessible rotary knobs.

 Due to its low power consumption and heat sink, the SAMI-402 does not need any fan cooling. However, avoid installing it in dusty environments and/or in a location with extreme temperature and moisture.

 The mixer should be kept apart from noise and interference sources (dimmers, motors, etc...) as well as from power cables.

The SAMI-402 is powered by alternating current through its external power supply: 100-240 VAC and 50-60 Hz. This external PSU has interchangeable connectors: American, European, British and Chinese.

| |
|---|
|  |
| PRECAUTIONS |
| WARRANTY & ENVIRONMENT |
| PACKAGE CONTENTS |
| DESCRIPTION & FEATURES |
| INSTALL & CONNECT |
| START-UP & OPERATION |
| PANEL FUNCTIONS |
| TECHNICAL DATA |

6. START-UP & OPERATION

6.1 Connections

6.1.1 Inputs

SAMI-402 supports two types of audio signals for each of its first three inputs (mono MIC or stereo LINE), selectable by a MIC/LINE switch on the rear panel.

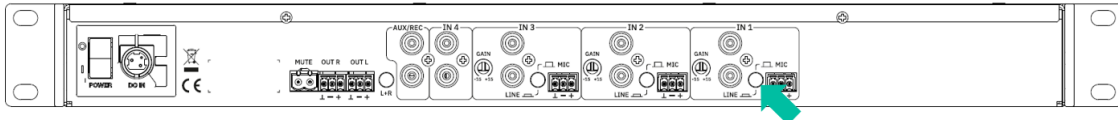

Microphone signal: 3 mixing channels offer a Euroblock connector for a nominal input level from -50dBV (3.16mV) to -20dBV (0.1mV), with a GAIN control on the rear panel to adjust the gain.

Wiring diagram for microphones:

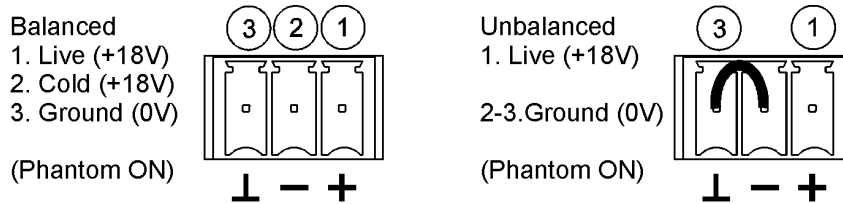

! Microphones must be low impedance (200 to 600 Ω) and monophonic.

The SAMI-402 supplies phantom power for condenser microphones; it is enabled by an **internal jumper** (see diagram below).

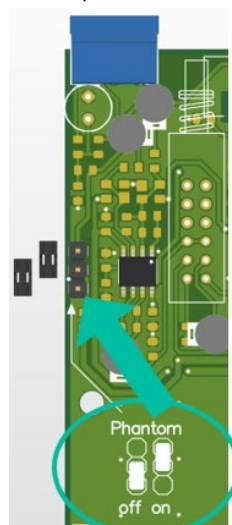

💡 By default, phantom power is disabled (factory setting).

| | |
|---|------------------------|
| 🏠 | PRECAUTIONS |
| 🔧 | WARRANTY & ENVIRONMENT |
| 📦 | PACKAGE CONTENTS |
| 📄 | DESCRIPTION & FEATURES |
| 🔌 | INSTALL & CONNECT |
| 🔧 | START-UP & OPERATION |
| 📄 | PANEL FUNCTIONS |
| 📄 | TECHNICAL DATA |

The **Talkover (priority)** function operates when a signal is detected at the inputs 1 to 3 **this function is assigned to**; it attenuates the other inputs of the unit that don't have priority. Turn it on/off for each input channel with the “tk” switch on the front panel.

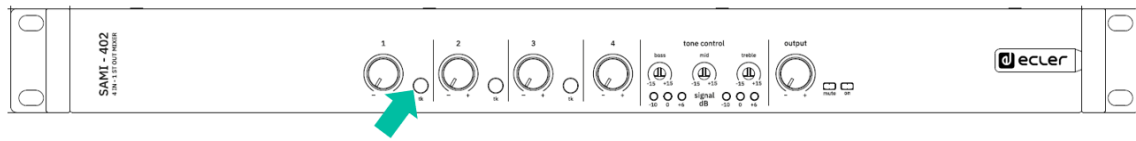

To manage the important level differences existing between conventional CD and LINE sources and other devices capable of producing audio signals, the LINE inputs 1-3 of the SAMI-402 are standard line inputs (0dBV) and the sensitivity of the LINE input 4 can be selected (0/-6dBV) by internal jumper (the default position is 0dBV). A sensitivity of -6dBV is ideal for low-level sound sources such as media players, portable MP3 players, tablets, computers, mobile phones, etc.

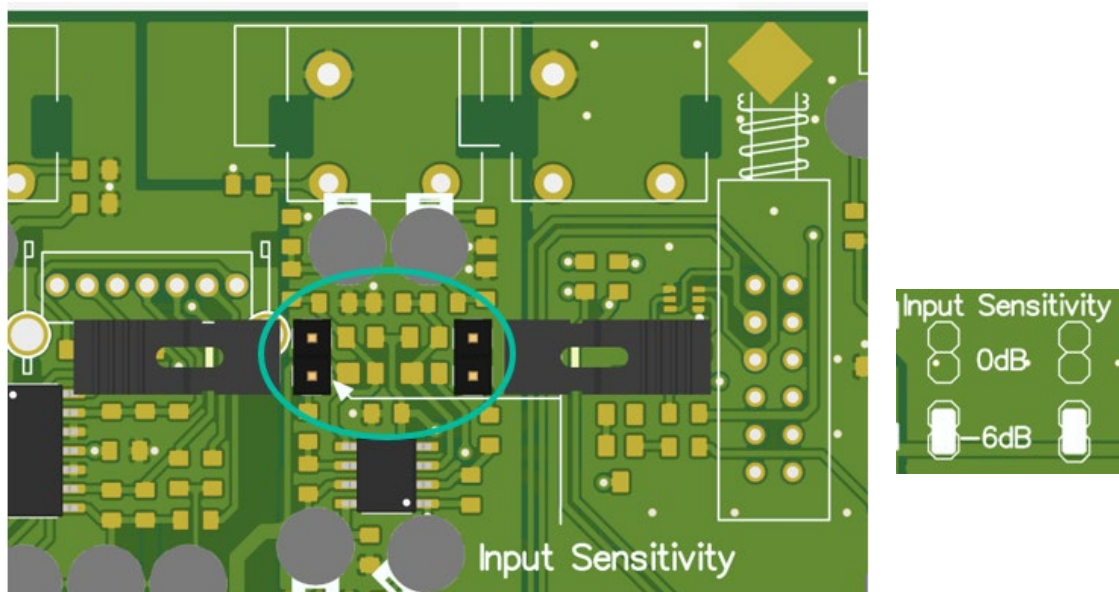

! Turntables cannot be directly connected to this unit, because SAMI-402 has no RIAA preamp equipped input.

- PRECAUTIONS
- WARRANTY & ENVIRONMENT
- PACKAGE CONTENTS
- DESCRIPTION & FEATURES
- INSTALL & CONNECT
- START-UP & OPERATION
- PANEL FUNCTIONS
- TECHNICAL DATA

6.1.2 Outputs

The SAMI-402 has a main stereo output (OUT L / OUT R), with electronically balanced Euroblock connectors.

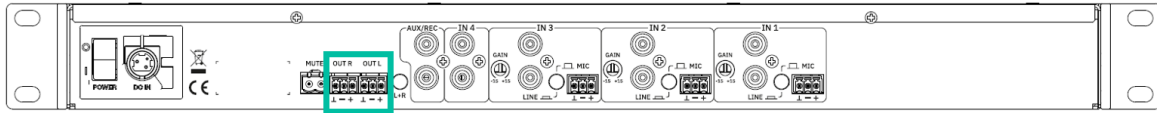

Connection is made according to the following diagram:

Balanced
1. Live
2. Cold
3. Ground

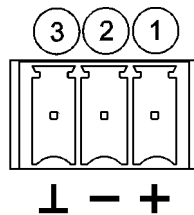

Unbalanced
1. Live
3. Ground

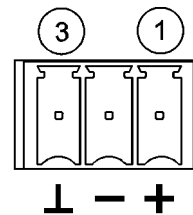

The mixer's main output level (OUTPUT VOL) must be set in order to avoid your system power amp clipping indicators (CLIP) to be permanently lit. Only the most powerful lower frequencies must light them.

The Aux Output has a jumper allowing to select between Aux Pre or Aux Post mode:

- Aux Pre mode:** the Aux Output is just a copy of the Main Output content. It means that the output level will always be 0dBV, regardless of whether the "Output Sensitivity" jumper is activated or not.
- Aux Post mode:** the Aux Output is an exact copy of the Main Output and both will have the same output level, i.e. 0dBV if the "Output Sensitivity" jumper is not activated or with an increase of +6db if it is activated.

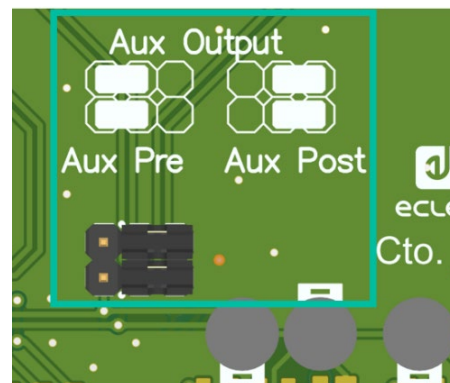

| |
|------------------------|
| |
| PRECAUTIONS |
| WARRANTY & ENVIRONMENT |
| PACKAGE CONTENTS |
| DESCRIPTION & FEATURES |
| INSTALL & CONNECT |
| START-UP & OPERATION |
| PANEL FUNCTIONS |
| TECHNICAL DATA |

6.1.3 Other connections on the back panel

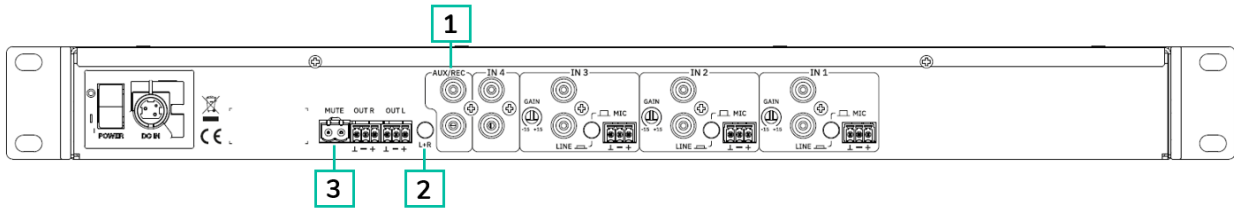

1. **AUX/REC output** with a nominal output of 0dBV (10kΩ load) and an extra gain setting of +6dB, enabled by internal jumper (0dBV is the default position).

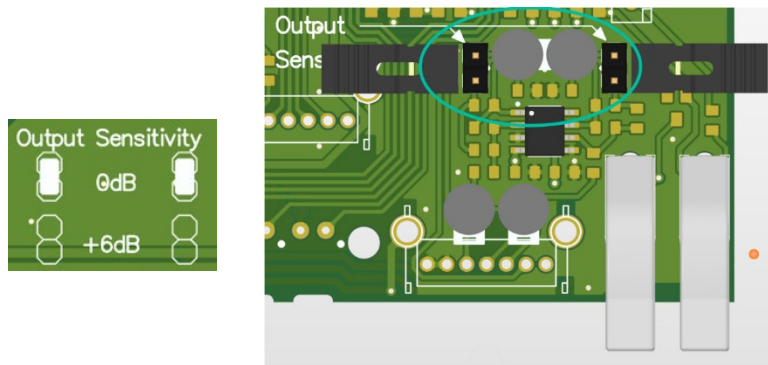

! Please note that the “Output Sensitivity” selector always affects the main output.

2. **L+R switch:** convert output signals in a mono signal.
3. **MUTE remote control input:** enabled by external dry contact closure. It allows connection of fire detection systems and other safety devices that have to mute the mixer by using this control signal. The mode of operation is "NO" (normally open).

| | |
|--|------------------------|
| | PRECAUTIONS |
| | WARRANTY & ENVIRONMENT |
| | PACKAGE CONTENTS |
| | DESCRIPTION & FEATURES |
| | INSTALL & CONNECT |
| | START-UP & OPERATION |
| | PANEL FUNCTIONS |
| | TECHNICAL DATA |

6.2 Starting-up

Plug the external PSU to the DC IN connector located on the rear panel and then, after connecting it to the power outlet, press the on/off switch to power the unit.

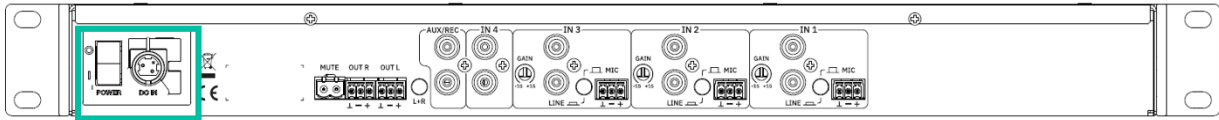

Even the power-up noise of SAMI-402 is minimal, we highly recommend to power up all equipment in the following order:

1. sound sources,
2. mixing units,
3. equalizer,
4. processors, and finally
5. power amplifiers.

The power down sequence is the inverse of the power up one.

6.3 Equalization

The tone controls of the main output provide a $\pm 15\text{dB}$ gain/attenuation for each of the bands, and their central operating frequencies are 100Hz, 2kHz and 10kHz. Given the philosophy of this unit, the tone controls are designed to be adjusted with a screwdriver, thereby preventing accidental manipulation during normal use.

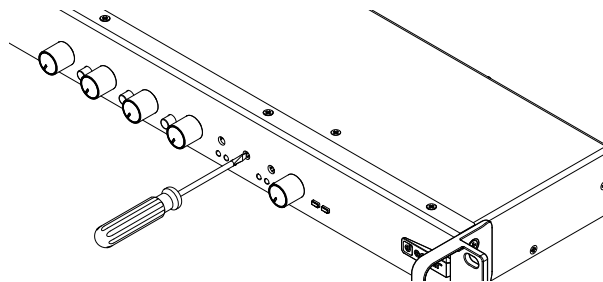

6.4 VU-Meter

The SAMI-402 has a VU-meter to show the main mixing signal.

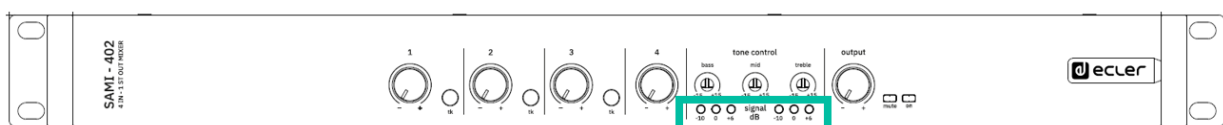

| | |
|--|------------------------|
| | PRECAUTIONS |
| | WARRANTY & ENVIRONMENT |
| | PACKAGE CONTENTS |
| | DESCRIPTION & FEATURES |
| | INSTALL & CONNECT |
| | START-UP & OPERATION |
| | PANEL FUNCTIONS |
| | TECHNICAL DATA |

6.5 Ground Loops, Background noise

! Please always make sure that the signal sources coming to the unit, as well as all devices connected to its outputs, do not have their grounds interconnected, that is; ground must never come from two different devices. Should this ever happen, noises could occur and seriously interfere the sound quality.

! Cable shields, when connected to the chassis, must never be linked together. This will avoid ground loops.

The SAMI-402 mixer has been designed to produce the lowest background noise. Independently from the electronic design, the resulting background noise directly relies on the correct use and installation of the mixing unit.

Adjust, where appropriate, the gain of each input for an adequate operating level and then adjust the VOL controls on the front panel to obtain the desired input mix.

Finally, **adjust the VOL control of the main mix output to get the relevant output volume for your installation, and also enable the TK switches for priority inputs** (a signal detection on these priority inputs will attenuate the signal of non-priority inputs).

! **Important note on mix level adjustment:** setting for example a channel VOL control to "2" and the output VOL control to "10" is not the same as the opposite. In the first case, the signal entering the mixing amplifier is weak, but even so it contains a background noise, so the signal/noise ratio is low (low signal). When the output amplifier equally amplifies both parts as a whole, the output has a very high background noise. In the second case, as the channel VOL control is set to the maximum, the signal received by the mixing amplifier has a high level and therefore also a high (good) signal/noise ratio, so when this signal reaches the output VOL control and is amplified, the signal/noise ratio remains better than in the previous case.

| |
|---|
|  |
| PRECAUTIONS |
| WARRANTY & ENVIRONMENT |
| PACKAGE CONTENTS |
| DESCRIPTION & FEATURES |
| INSTALL & CONNECT |
| START-UP & OPERATION |
| PANEL FUNCTIONS |
| TECHNICAL DATA |

7. PANEL FUNCTIONS

7.1 Front Panel

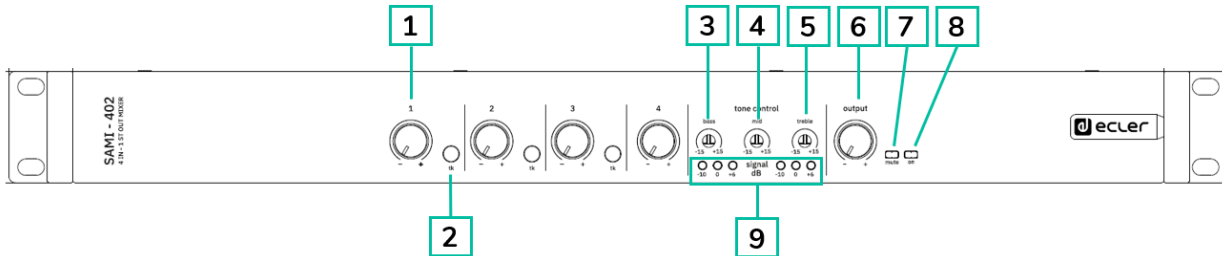

- | | |
|--|---|
| <ol style="list-style-type: none"> 1. Channel volume control, VOL x4 2. Talkover switch, tk x3 3. Bass control, BASS 4. Midrange control, MID 5. Treble control, TREBLE | <ol style="list-style-type: none"> 6. Output main volume control, OUTPUT VOL 7. LED indicator, MUTE 8. LED indicator, POWER ON 9. Led Vu-meter, LEVEL |
|--|---|

7.2 Rear Panel

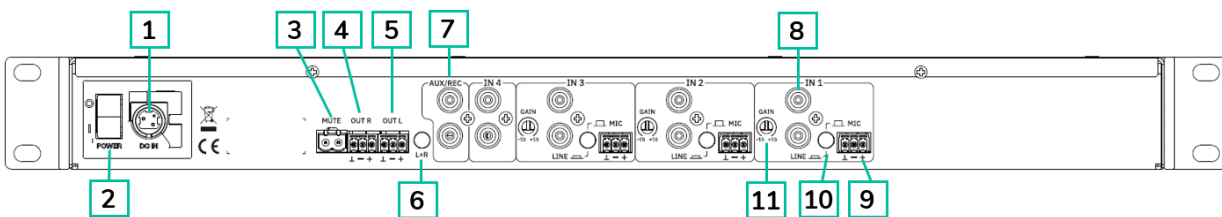

- | | |
|---|--|
| <ol style="list-style-type: none"> 1. Mains socket 2. Mains switch, POWER 3. Screwable terminal for remote mute, MUTE 4. Main output, right channel, OUTPUT R 5. Main output, left channel, OUTPUT L | <ol style="list-style-type: none"> 6. Mono-stereo switch, L+R 7. Recording output, AUX/REC 8. Line input, LINE x4 9. Micro input, MIC x3 10. Micro line selector x3 11. Input sensitivity adjust, GAIN x 3 |
|---|--|

| |
|------------------------|
| PRECAUTIONS |
| WARRANTY & ENVIRONMENT |
| PACKAGE CONTENTS |
| DESCRIPTION & FEATURES |
| INSTALL & CONNECT |
| START-UP & OPERATION |
| PANEL FUNCTIONS |
| TECHNICAL DATA |

8. TECHNICAL DATA

8.1 Technical Specifications

SAMI-402

| ANALOGUE AUDIO INPUT PORTS | |
|-----------------------------|--|
| Number of input ports | 3, MIC/LINE 1, LINE |
| Connection type | MIC: 3-pin Euroblock LINE: RCA |
| Input sensitivity | LINE 1-3: 0dB LINE 4: 0dB/-6dB (internally selectable) MIC 1-3 BAL: -35dB |
| Input sensitivity adjust | MIC/LINE: ±15dB |
| Input impedance | LINE 1-3: 50kΩ LINE 4: 50kΩ MIC 1-3 BAL: >1kΩ |
| CMRR | MIC: >60dB @ 1 kHz |
| Phantom voltage | +18VDC |
| ANALOGUE AUDIO OUTPUT PORTS | |
| Number of output ports | 1 main mix output 1 AUX/REC output |
| Connection type | Main: 3-pin Euroblock AUX/REC: RCA |
| Output type | 1 STEREO/2 MONO main mix output 1 STEREO AUX/REC |
| Nominal output level | OUT: 0dB/+6dB (internally selectable) AUX/REC: 0dB/+6dB (follows MAIN OUT, when AUX OUT=POST) |
| Output impedance | OUT: 600Ω AUX/REC: 10kΩ |
| SIGNAL | |
| Frequency response | LINE: 10Hz-50kHz -1dB MIC BAL: 10Hz-30kHz -1dB |
| THD + Noise | LINE: <0.005% MIC BAL: <0.04% |
| Signal noise ratio | LINE: >100dB MIC BAL: >85dB |
| DEVICE CONTROL | |
| Tone Control | 3-way tone control |
| Tone Frequency Cut | BASS: 100Hz ±15dB MID: 2kHz ±15dB TREBLE: 10kHz ±15dB |
| Talkover | TIME: 2 seconds EFFECT: -30dB |
| Control Buttons | Power ON, Talkover, LINE/MIC, L+R (output), Gain knob, Volume knob |
| Status Indicators | Power ON LED, MUTE LED, Vu-meter LEVEL LEDs |
| REMOTE CONTROL CONNECTIONS | |
| GPIs | MUTE control port NO/NC |



PRECAUTIONS

WARRANTY & ENVIRONMENT

PACKAGE CONTENTS

DESCRIPTION & FEATURES

INSTALL & CONNECT

START-UP & OPERATION

PANEL FUNCTIONS

TECHNICAL DATA

| ELECTRICAL | |
|-----------------------------|--|
| Power supply | ±17.5VDC External PSU |
| AC mains requirement | 100-240 V @ 50-60Hz (External PSU: 17.5VDC) |
| AC mains connector | IEC inlet connector |
| Power consumption | 10.8VA / 4.5W |
| Cooling | Passive |
| PHYSICAL | |
| Operating temperature | Min: -10°C ; 14°F Max: 40°C ; 104°F |
| Operating humidity | <85% HR |
| Storage temperature | Min: -10°C ; 14°F Max: 40°C ; 104°F |
| Storage humidity | <90% HR |
| Installation options | 19" rack format (1RU) |
| Included accessories | ±17.5VDC multi-plug PSU, EuroBlocks, Rubber Foot, Mini Jumpers |
| Dimensions (WxHxD) | 482.6 x 155 x 44 mm / 19 x 6.10 x 1.73 in |
| Weight | 1.75 kg / 3.86 lb |
| Shipping dimensions (WxHxD) | 560 x 60 x 295 mm / 22.05 x 2.36 x 11.61 in |
| Shipping weight | 2.45 kg / 5.40 lb |

| |
|---|
|  |
| PRECAUTIONS |
| WARRANTY & ENVIRONMENT |
| PACKAGE CONTENTS |
| DESCRIPTION & FEATURES |
| INSTALL & CONNECT |
| START-UP & OPERATION |
| PANEL FUNCTIONS |
| TECHNICAL DATA |

8.2 Mechanical Diagram

All measurements are in mm.



Ecler SAMI-402 Mechanical Diagram

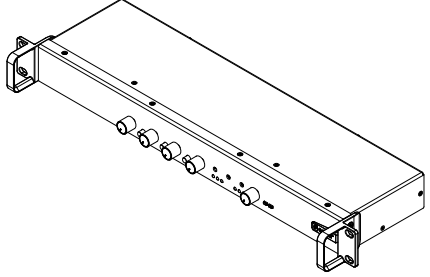

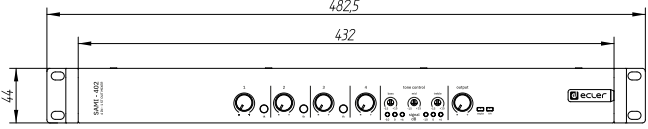



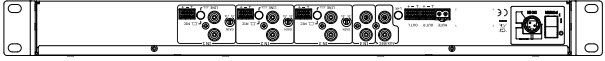

All the measurements are in mm.

6I-1136-0100

www.ecler.com



PRECAUTIONS

WARRANTY & ENVIRONMENT

PACKAGE CONTENTS

DESCRIPTION & FEATURES

INSTALL & CONNECT

START-UP & OPERATION

PANEL FUNCTIONS

TECHNICAL DATA

| |
|---|
|  |
| PRECAUTIONS |
| WARRANTY & ENVIRONMENT |
| PACKAGE CONTENTS |
| DESCRIPTION & FEATURES |
| INSTALL & CONNECT |
| START-UP & OPERATION |
| PANEL FUNCTIONS |
| TECHNICAL DATA |



All product characteristics are subject to variation due to production tolerances. **NEEC AUDIO BARCELONA S.L.** reserves the right to make changes or improvements in the design or manufacturing that may affect these product specifications.

For technical queries contact your supplier, distributor or complete the contact form on our website, in [Support / Technical requests](#).

Motors, 166-168 | 08038 Barcelona, Spain | Tel. (+34) 932238403 | information@ecler.com | www.ecler.com