

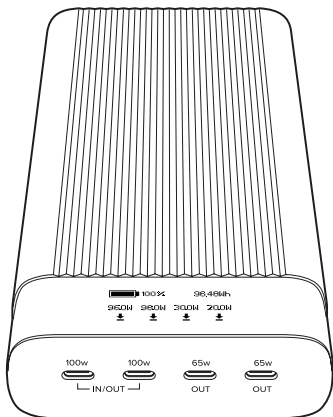

# HYPERJUICE® 245W USB-C Battery Pack



**USER GUIDE**

# Table of Contents

<b>Copyright</b>	<b>1</b>
<b>Trademarks</b>	<b>1</b>
<b>Regulatory Compliance</b>	<b>2</b>
FCC Conditions	2
CE	2
WEEE Information	2
<b>Introduction</b>	<b>3</b>
<b>Package Contents</b>	<b>3</b>
<b>Product Overview</b>	<b>4</b>
<b>How to Connect</b>	<b>5</b>
<b>Recharging HyperJuice</b>	<b>6</b>
<b>Safety Instructions</b>	<b>7</b>
<b>OLED Display</b>	<b>8</b>
<b>Power Distribution</b>	<b>9</b>
<b>Specifications</b>	<b>10</b>

Before attempting to connect, operate or adjust this product, please save and read the User Guide completely. The style of the product shown in this User Guide may be different from the actual unit due to various models.

## Copyright

This document contains proprietary information protected by copyright. All rights are reserved. No part of this guide may be reproduced by any mechanical, electronic or other means, in any form, without prior written permission of the manufacturer.

## Trademarks

Hyper, the ++Hyper logo, and HyperJuice, are trademarks or registered trademarks of Targus International LLC in the U.S. and in certain other countries. All logos and registered trademarks are the property of their respective owners.

© 2022 Targus International LLC, 1211 North Miller Street, Anaheim, CA 92806 USA. All rights reserved.

# Regulatory Compliance

## FCC Conditions

This equipment has been tested and found to comply with Part 15 Class B of the FCC Rules. Operation is subject to the following two conditions: (1) This device may not cause harmful interference. (2) This device must accept any interference received and include interference that may cause undesired operation.

## CE

This equipment is in compliance with the requirements of the following regulations: EN 55032/EN 55024: CLASS B

## WEEE Information

For EU (European Union) member users: According to the WEEE (Waste electrical and electronic equipment) Directive, do not dispose of this product as household waste or commercial waste. Waste electrical and electronic equipment should be appropriately collected and recycled as required by practices established for your country. For information on recycling of this product, waste disposal service or the shop where you purchased the product.



CAN (B)/NMB-3(B)

# Introduction

The HyperJuice 245W USB-C Battery Pack is the world's first 27000mAh, 100 watt-hour, 245W USB-C Battery Pack that's designed to be airline-safe and super portable.

## Package Contents

- HyperJuice 245W USB-C Battery Pack
- 3ft/90cm USB-C Charging Cable
- User Guide

# Product Overview

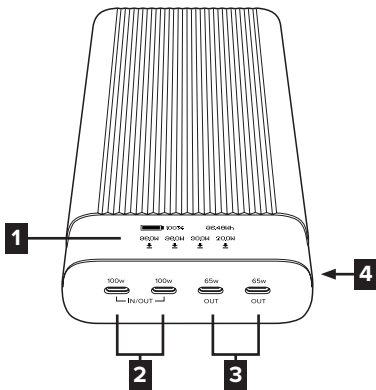

Item	Description
1. OLED Display	Shows the Battery Pack's power and charging status
2. USB-C Port (100W Max)	Connects to USB-C device and charges up to 100W
	Recharges Battery Pack with a USB-C PD power adapter
3. USB-C Port (65W Max)	Connects to USB-C device and charges up to 65W
4. OLED Display On/Off Button	Allows you to turn on or turn off the OLED Display

# How to Connect

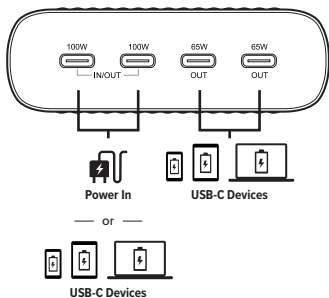

# Recharging HyperJuice

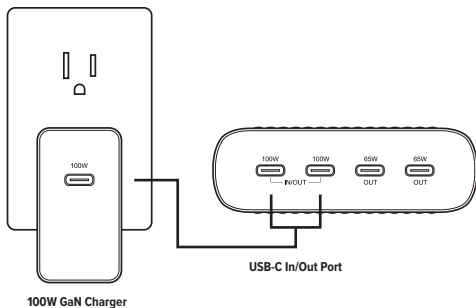

100W USB-C PD charger is recommended for fast recharging of the Battery Pack. We'd suggest the HyperJuice 100W GaN Charger or the HyperJuice 245W GaN Desktop Charger.



# Safety Instructions

- Store in a cool, dry place. Recommended storage temperature: -20°C/-4°F to 45°C/113°F (< 3 months); -20°C/-4°F to 25°C/77°F (< 12 months); Operating temperature: 0°C/32°F to 30°C/86°F.
- Do not disassemble or attempt to re-purpose or modify the product in any manner.
- Stop using and contact manufacturer if the product is excessively hot, is emitting odor, deformed or if you witness any other abnormalities.
- Do not operate your battery in an enclosed or unventilated environment, such as a carrying bag, pocket or purse, to prevent overheating.
- Fully charge your external battery before using it for the first time.
- Be cautious of drops, bumps, abrasions, or impact.
- Do not clean with harmful chemicals or detergents.
- Use origin or certified cables.
- Do not expose to moisture or submerge it in liquid.
- Keep away from children under 3 years old for safety.
- Please dispose of discarded products properly according to local regulations.

# OLED Display

Press the OLED Display On/Off Button to turn the display on or off.

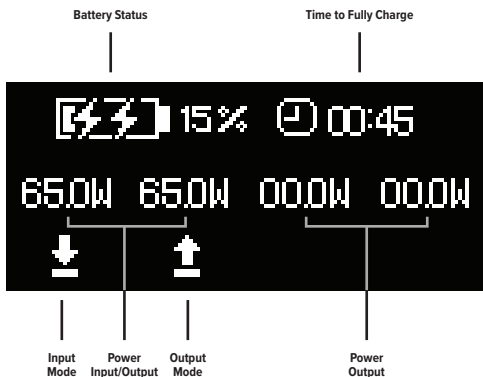

# Power Distribution

Priority	1	2	3	4	
Port	C1	C2	C3	C4	Total*
1	100W				100W
		100W			100W
			65W		65W
				65W	65W
2	100W	100W			200W
	100W		65W		165W
	100W			65W	165W
		100W	65W		165W
		100W		65W	165W
			65W	65W	130W
3	100W	100W	45W		245W
	100W	65W	65W		230W
	100W	100W		45W	245W
	100W	65W		65W	230W
	100W		65W	65W	230W
		100W	65W	65W	230W
4	100W	100W	30W	15W	245W
	100W	65W	65W	15W	245W
	65W	60W	60W	60W	245W
	65W	100W	65W	15W	245W

\*Charging rates may vary depending on the devices you're charging.

# Specifications

Power Capacity:	100Wh/27000mAh
Battery Cell:	Lithium Ion
Power Input:	Max 100W USB-C Power Delivery
Max Total Power Output:	245W
Ports:	4 x USB-C
USB-C1/C2:	IN/OUT, Max 100W, PD3.0 5V/3A, 9V/3A, 12V/3A, 15V/3A, 20V/3A, 20V/5A PPS:3.3V-11V/3A; 5V-21V/5A
USB-C3/C4:	OUT, Max 65W, PD3.0 5V/3A, 9V/3A, 12V/3A, 15V/3A, 20V/3A, 20V/3.25A
Protocol:	PD2.0/3.0, PPS, QC2.0/3.0/4.0+, Apple 2.4A, BC1.2, AFC, FCP (C1 & C2) PD2.0/3.0, QC2.0/3.0, Apple 2.4A, BC1.2, AFC, FCP (C3 & C4)
Passthrough Charging:	Recharge battery pack and connected devices at the same time
Protection:	Over-current, Over-voltage, Over-temperature, Short-circuit Protection
Dimensions:	Length: 191 mm / 7.51 inches Width: 81 mm / 3.18 inches Height: 28 mm / 1.10 inches
Weight:	765g / 1.69lbs

(This page is intentionally blank)

# **1 YEAR LIMITED WARRANTY**

UK AND EU CUSTOMERS: 2 YEAR LIMITED WARRANTY OR AS REQUIRED BY LOCAL LAWS.

PORTUGAL AND SPAIN CUSTOMERS: 3 YEARS LIMITED WARRANTY OR AS REQUIRED BY LOCAL LAWS.

We pride ourselves on the quality of our products. For complete warranty details and a list of our Worldwide offices, please visit [www.HyperShop.com](http://www.HyperShop.com). Hyper product warranty does not cover any device or product that is not manufactured by Hyper (including, but not limited to, laptops, smartphones, devices, or any other product that may be used in connection with the Hyper product). Hyper Limited Warranty provided is subject to any rights and remedies the purchaser may have under local laws. Australian customers: For complete warranty details, see warranty statement enclosed.

# **GARANTIE LIMITÉE DE 1 AN**

CLIENTS DU ROYAUME-UNI ET DE L'UE : GARANTIE LIMITÉE DE 2 ANS OU SELON LA LÉGISLATION LOCALE.

CLIENTS DU PORTUGAL ET DE L'ESPAGNE : GARANTIE LIMITÉE DE 3 ANS OU SELON LES LOIS LOCALES.

Nous sommes fiers de la qualité de nos produits. Pour obtenir les détails complets de la garantie et la liste de nos bureaux dans le monde, veuillez consulter le site [www.HyperShop.com](http://www.HyperShop.com). La garantie des produits Hyper ne couvre aucun appareil ou produit qui n'est pas fabriqué par Hyper (y compris, mais sans s'y limiter, les ordinateurs portables, les smartphones, les appareils ou tout autre produit pouvant être utilisé en relation avec le produit Hyper). La garantie limitée Hyper fournie est soumise à tous les droits et recours dont l'acheteur peut disposer en vertu des lois locales. Clients australiens : Pour les détails complets de la garantie, voir la déclaration de garantie jointe.

# **1 AÑO DE GARANTÍA LIMITADA**

CLIENTES DEL REINO UNIDO Y DE LA UE: 2 AÑOS DE GARANTÍA LIMITADA O LA ESTIPULADA POR LA LEGISLACIÓN LOCAL.

CLIENTES DE PORTUGAL Y ESPAÑA: 3 AÑOS DE GARANTÍA LIMITADA O LA ESTIPULADA POR LA LEGISLACIÓN LOCAL.

Estamos orgullosos de la calidad de nuestros productos. Para obtener información acerca de la garantía completa y consultar nuestra lista de oficinas en todo el mundo, visite [www.HyperShop.com](http://www.HyperShop.com). La garantía del producto de Hyper no cubre ningún dispositivo o producto que no haya sido fabricado por Hyper (incluyendo, entre otros, ordenadores portátiles, smartphones, dispositivos o cualquier otro producto que pueda utilizarse con el producto de Hyper). La Garantía Limitada de Hyper proporcionada está sujeta a cualquier derecho y recurso que el comprador pueda tener según la legislación local. Clientes australianos: Para obtener información acerca de la garantía completa, consulte la declaración de garantía adjunta.

## **AUSTRALIAN AND NEW ZEALAND CONSUMERS ONLY**

Thank you for your purchase. Hyper warrants to the original purchaser that its products are free from defects in materials and workmanship and, during the specified warranty period, and lasts as long as the original purchaser owns the product. The warranty period is stated on the packaging or in the documentation provided with this Hyper product. Hyper's Limited Product Warranty excludes damage caused by accident, neglect, abuse, misuse, improper care, normal wear and tear, ownership transfer, or alteration. The limited warranty also excludes any product that is not manufactured by Hyper (including, without limitation, laptops, smartphones, devices, tablets, or any other non-Hyper item) that is used in connection with the Hyper product. In the event that the Hyper product has a defect in materials or workmanship Hyper will, after receiving a warranty claim and inspecting the product, at its discretion, do one of the following: repair, replace, or refund with the same or a similar product (or part) of no lesser quality and ship it to the original purchaser at Hyper's expense. As part of this inspection, proof of purchase will be required. There is no charge for inspection. To make a warranty claim, please contact Hyper Australia or New Zealand (see details below), or return the product to the place of purchase. The original purchaser must bear the cost of the delivery to Hyper. Under Australian and/or New Zealand Consumer Laws, in addition to any warranty Hyper gives, our products come with guarantees that cannot be excluded. You are entitled to a replacement or refund for a major failure and compensation for any other reasonably foreseeable loss or damage. You are entitled to have the products repaired or replaced if they fail to be of acceptable quality and the failure does not amount to a major failure.

For any warranty question, contact Targus Australia Pty. Ltd. (i) by mail at Suite 2, Level 8, 5 Rider Boulevard, Rhodes NSW 2138, by phone AUS 1800 641 645 or NZ 0800 633 222 or by Email: [infoaust@targus.com](mailto:infoaust@targus.com). For additional information, check out our website at [targus.com/au/warranty](http://targus.com/au/warranty).



# TECHNICAL SUPPORT

**For technical questions, please visit:**

Hyper Customer Support Email: [support@hypershop.com](mailto:support@hypershop.com)

Hyper Customer Support Phone:

1-888-202-1888 (USA); +1-408-737-7878 (non-USA)

US Internet: <http://targus.com/us/support>

Canada Internet: <http://www.targus.com/ca/support>

Australia Internet: <http://www.targus.com/au/support>

Email: [infoaust@targus.com](mailto:infoaust@targus.com)

Telephone: 1-800-641-645

New Zealand Telephone: 0800-633-222

Latin America Email: [latam.soporte@targus.com](mailto:latam.soporte@targus.com)

(This page is intentionally blank)

(This page is intentionally blank)

